

TILTMETER DATASHEET

THE SYSTEM: SMART SHM

Move Solutions is a trusted leader in **Smart Structural Health Monitoring (Smart SHM)**. Our wireless system offers a remote, continuous and comprehensive analysis of the health of the structures. By integrating cutting-edge **Internet of Things (IoT)** technology with Structural Health Monitoring practices we promote more sustainable and resilient infrastructure.

KEY PARAMETERS

- Easy installation on the structure
- Minimum maintenance required
- Long-range communication
- Fully remote management and customization
- Data analysis with advanced algorithms
- Modular system
- High precision
- Waterproof rating IP67
- Long-life battery
- Integrated temperature sensor

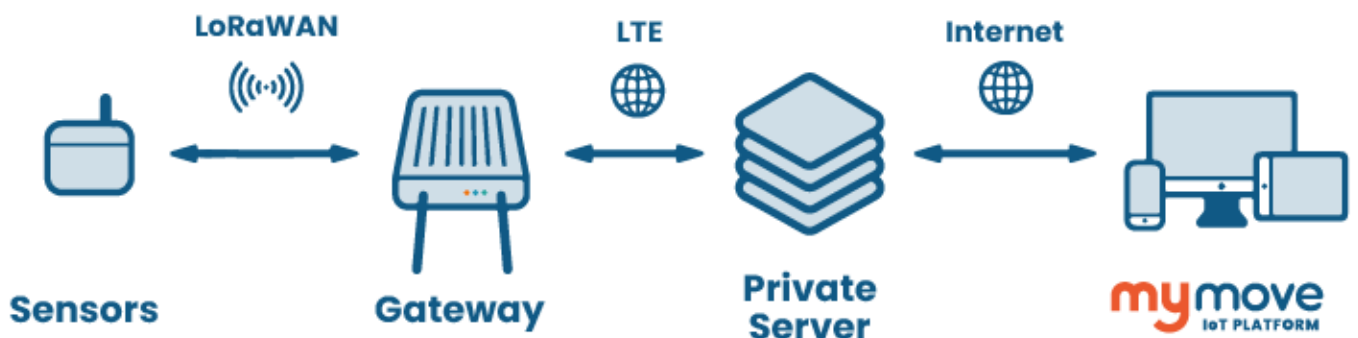

HOW IT WORKS

Move Solutions offers a wireless monitoring system for *static, dynamic, geotechnical and environmental analysis* of all civil infrastructures: bridges, construction sites, rails, and more. Small **battery-powered sensors** combined with **MyMove IoT Platform** and highly **advanced algorithms** provide a comprehensive monitoring solution aimed at simplifying asset management. The data recorded by the sensors can be viewed on Move Solutions MyMove IoT Platform, which allows users to remotely monitor and manage structures in real time. They can set different operating parameters of each sensor, such as sampling rates, resolution and full scale, alarm and activation thresholds, and much more. That allows users to detect structural damage in time to implement preventive maintenance and reduce costs. Move Solutions system empowers infrastructure owners with insights to promote a proactive monitoring approach for safer, more sustainable, and resilient infrastructures.

ADVANTAGES

- Reduction of manual and on-site measurements
- Reduced downtime and disruptions to regular operations
- Real-time, remote and continuous data visualization
- Short-term and long-term data analysis
- Easy addition of sensors to extend the monitored area
- Cost reduction thanks to easy installation and maintenance
- Risk reduction and high reliability
- Preventive maintenance

THE DEVICE: TILTMETER

The Tiltmeter measures the variation of the static angular inclination of the structure with respect to the horizontal plane, i.e. perpendicular to the gravitational axis. By installing an entire system it is possible to reconstruct the static deflection of the structure. All Tiltmeters can be synchronized with each other, which is perfect for static load tests. The Tiltmeter also measures temperature. It is battery powered and has a LoRaWAN wireless transmission. The data acquisition methods can be set by the user through MyMove IoT Platform.



OUTPUT TILTMETER

The Tiltmeter outputs angles that describe the variation in inclination of the body on which the device is installed. The calculation of these angles is based on the projections of the gravity vector on the three axes of the sensor, averaged over an acquisition interval of 16 seconds. The sensor also acquires the temperature. By installing an entire system it is possible to reconstruct the static deflection of the structure during a load test.

To have a precise and accurate view of the three-dimensional movement of the structure on which the Tiltmeter device has been installed, it is necessary to observe two different angles provided by the device, "Phi - φ " and "Theta - θ ", in pairs or, alternatively, a third angle defined as "3D variation angle".

φ - PHI ANGLE

It represents the angle between the Z axis, represented on the orientation label, and its projection on the horizontal plane.

θ - THETA ANGLE

It represents the angle between the Y axis, represented on the orientation label, and its projection on the horizontal plane.

DOWNLOAD DOCUMENTATION

Visit the website at www.movesolutions.it to download further documentation relating to technical specifications and/or information on the Move Solutions™ structural monitoring system.

$\Delta\varphi - \Delta\theta$ - INCLINATION COMPENSATION

With the Web Platform provided by Move Solutions™, it is possible to activate or deactivate (it is activated by default) a feature called “Data compensation”, thanks to which compensation is activated with respect to the installation position. In this way, it is possible to view the variation of inclination of the structure. The data displayed in the respective graphs therefore refer to the angular variations of Phi ($\Delta\varphi$) and Theta ($\Delta\theta$) with respect to the initial installation position.

If the “Data Compensation” feature is deactivated, the Web Platform will display the absolute angles with respect to the horizontal plane. These absolute angles may carry on measurement errors caused by an incorrect installation not completely parallel to the horizontal plane of the Tiltmeter device. It is recommended to keep the “Data compensation” option always active; the measurement of the variation ($\Delta\varphi$ and $\Delta\theta$) is to be considered more accurate.

THETA ANGULAR VARIATIONS

$\theta_2 - \theta_1 = \Delta\theta$

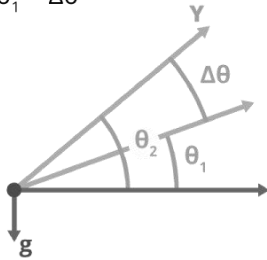

PHI ANGULAR VARIATIONS

$\varphi_2 - \varphi_1 = \Delta\varphi$

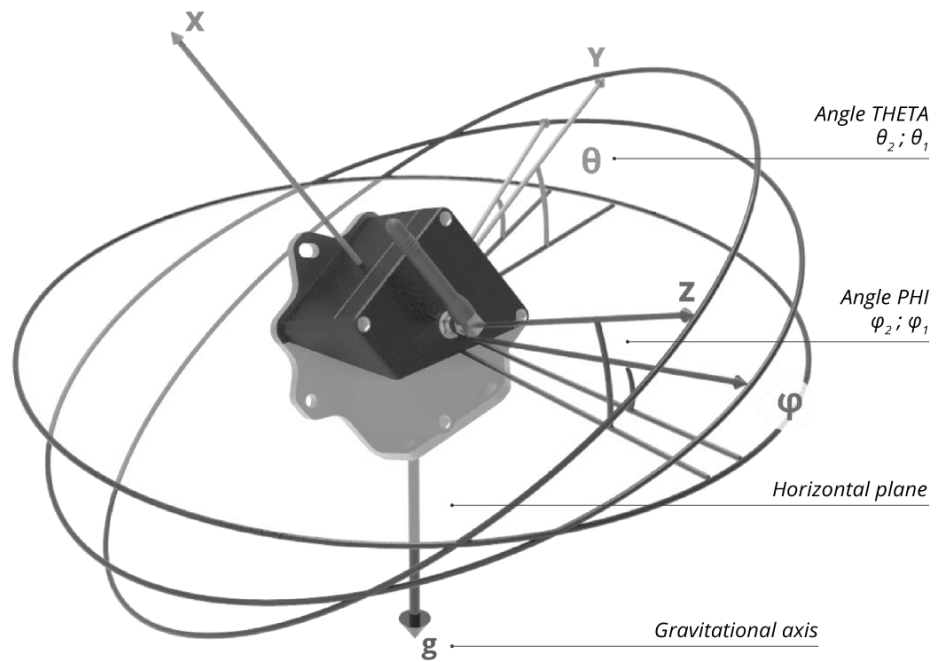
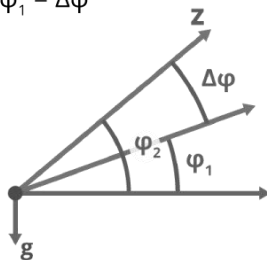

QUICK GUIDE TO USE

The triaxial Tiltmeter device is “plug and play”; by screwing the special antenna on the cover, the device will immediately start to detect and send data. To ensure correct operation, see

the chapter “Tiltmeter Orientation” and “Tiltmeter Installation Guide”, the Tiltmeter sensor must be correctly oriented and installed, following these specific steps:

1. ORIENTATION:

- The axes shown on the orientation label, which is placed on the sensor cover, must be aligned as the axes of interest of the structure.
- The X axis must always be oriented upwards.
- The X axis must be as parallel as possible to the gravitational axis.
- The plane formed by the Y - Z axis must be parallel to the horizontal plane.

2. INSTALLATION ON THE STRUCTURE:

- Agree with the supplier company on the correct place of installation on the structure of the Tiltmeter device.
- Firmly install the Tiltmeter on the wall, ceiling or floor using the special plate and screws/wall plugs supplied. It is possible to rotate the plate relative to the device to keep the X axis parallel to the gravitational axis and oriented upwards, regardless of the agreed installation location.
- To ensure correct installation, the X axis must have a maximum inclination of 85° with respect to the gravitation axis.
- Install all sensors on the structure before powering and turning on the Gateway device.

3. SCREWING THE ANTENNA:

- Before activating the Gateway, screw the LoRaWAN 868 MHz antenna onto the device cover.

After meeting these orientation and installation requirements, the Tiltmeter device will be able to detect and send data to the Gateway without interference or data alteration.

Verify, via the MyMove IoT Platform, the correct functioning of the sensor just installed. From the moment the Gateway is powered up, and therefore from the actual start-up and activation moment, a maximum waiting of about an hour is required before it is possible to correctly view all the sensors online.

CORRECT INSTALLATION

When installing the Tiltmeter sensor on the structure, make sure that the X axis (always oriented upwards) is positioned within the “Region of correct positioning”. The extent of the region of correct positioning is defined by the total sum of the possible inclinations in which the installation on the structure can be defined as correct. This totality of possible inclinations refers to the X axis of the Tiltmeter with respect to the absolute gravitational axis. We can therefore state that:

- In case of need due to an inclined surface, it is possible to install the device with the X axis having a maximum inclination of 85° with respect to the gravitational axis.
- The X axis must always be oriented upwards.

Figure 1 - Front view of the Tiltmeter
 Display of the “Region of correct positioning”.

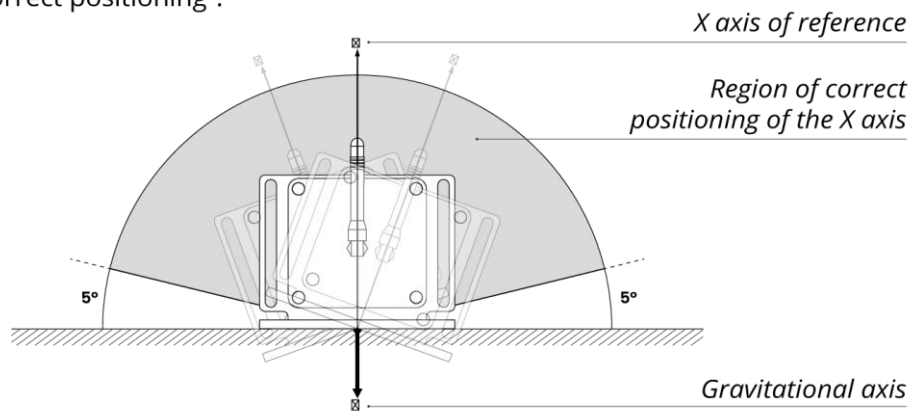
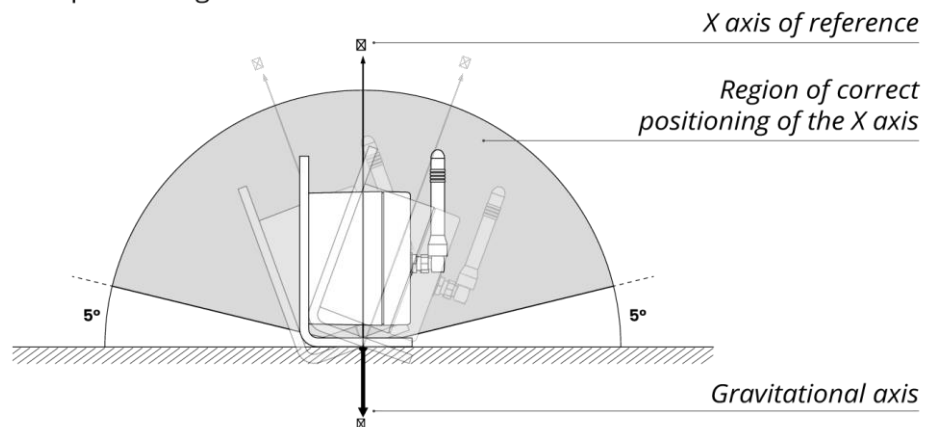

Figure 2 - Tiltmeter side view
 Display of the “Region of correct positioning”.



TECHNICAL SPECIFICATIONS

OPERATION

<p>Operation with programmed acquisitions</p>	<p>Record of a tilt sample at a fixed cadence as set by the user (once every 2 minutes, 5 minutes, 15 minutes, 30 minutes). Each sample of inclination is derived by averaging 16 seconds of observation. For each acquisition also the temperature is recorded.</p> <p>All sensors are synchronized in time in order to sample the structure at the same time. Acquisition start time is aligned to multiples of the acquisition cadence starting from 00:00. Examples:</p> <p>cadence is 2 minutes: 00.00, 00.02, 00.04, etc. cadence is 5 minutes: 00.00, 00.05, 00.10, etc. cadence is 15 minutes: 00.00, 00.15, 00.30, etc. cadence is 30 minutes: 00:00, 00:30, 01:00, etc.</p>
<p>Custom operation software</p>	<p>It is possible to request custom features that the client deems necessary for their business.</p>
<p>Synchronization accuracy</p>	<p>± 1 seconds</p>

MEASUREMENT

<p>Technology</p>	<p>MEMS technology – Triaxial</p>
<p>Acquisition of</p>	<ul style="list-style-type: none"> ▪ Tilt angle ▪ Temperature
<p>Resolution</p>	<p>0,000015°</p>
<p>Repeatability</p>	<p>±0,0005°</p>
<p>Accuracy</p>	<p>0,005°</p>
<p>Range</p>	<p>± 90° (on both angles)</p>
<p>Cross axis sensitivity</p>	<p>1%</p>
<p>Temperature resolution</p>	<p>0,125°C</p>

RADIO

<p>Radio channel</p>	<p>LoRaWAN communication protocol</p>
<p>Radio channel frequency</p>	<p>ISM 868Mhz</p>
<p>Link coverage*1</p>	<p>1 km (line of sight with the Gateway)</p>

GENERAL DATA

<p>Ingress protection*2</p>	<p>IP67</p>
------------------------------------	-------------

Battery	1 lithium battery type "D" 19Ah 3.6V
Operating temperatures	-40°C / +85°C
Dimensions	75 x 80 x 57 mm
Weight	1.1 Kg
Case material	Alloy GD-ALSi12
Corrosion resistance	>1000 hours in salt spray

INSTALLATION

Method	Two-point mounting using screws and plugs (Ø6mm, L:30mm)
Site	<ul style="list-style-type: none"> ▪ Fixing on wall ▪ Fixing on ceiling ▪ Fixing on ground

BATTERY LIFE

Acquisition mode	Estimated battery life* ³
Every 30 minutes	8 years

*1 Wireless coverage of the device may vary depending on the scenario.

*2 Guaranteed only with the dust cap or smart cable correctly screwed.

*3 Battery life may shorten when operating in extreme temperatures.

REVISION HISTORY

Version v4.

Version	Changelog
v1	First revision
v2	Improved accelerometer output description
v3	Document template update
v4	MyMove update (June 24)

Note: Specifications are subject to review and change without notice.